

# Installation Instructions

FITMENT

**Polaris  
RZR XP900  
2011-2013**

## BEFORE YOU START !!!!!

**BEFORE YOU REMOVE THE EXHAUST SYSTEM COMPONENTS from their plastic bags, make a note of the "right side" vs. "left side". The right side DMC muffler is identifiable by having four mounting brackets.**

## parts included

- (2) Mufflers
- (2) Headers
- (2) Mid Pipe
- (1) Muffler Hanger Bar
- (1) Hardware Kit

## tools required

- Pipe Spring Puller
- 10, 12mm box wrenches
- 5mm allen wrench
- To prevent leaks, we recommend replacement of the exhaust gasket upon installation.

Thank you for choosing to install the finest exhaust system available. DMC uses only the latest technology to deliver big gains in acceleration, horsepower and torque, while capturing additional strength and critical weight savings. Please read all instructions carefully and thoroughly before installing this system. Any references to "left" or "right" indicates sides as if you were sitting on the bike facing forward.

## REMOVAL PROCEDURE

1. Remove both seats completely.
2. Remove the plastic panel directly behind seats by rotating the two latches by hand. **SEE IMAGE #1**
3. Remove the stock muffler assembly.
4. Remove the stock header assembly by loosening the three (per side) stock socket head cap screws (allen head) that secure the exhaust flanges to the cylinder head. The header will only come out forward, through the passenger seat space.



**IMAGE 1**

## PRE-INSTALLATION

1. Install rubber grommets and aluminum axles from the DMC hardware kit into the DMC muffler mounts. Using warm water on the rubber grommets makes this easier. The shoulders on all of the aluminum axles must be installed towards the outside of the vehicle. **SEE IMAGE #2**
2. Position the DMC Muffler Hanger on a bench so that the tapered pin on your left. Then position the Right DMC muffler so that the muffler outlet is also facing left, and attach to the Muffler Hanger using the supplied hex head flange screws.
3. Attach the Left DMC muffler to (directly under) the Right DMC Muffler with the muffler outlet facing to the right, using the supplied hex head flange screws. Leave all muffler fasteners loose at this point. **SEE IMAGE #3**

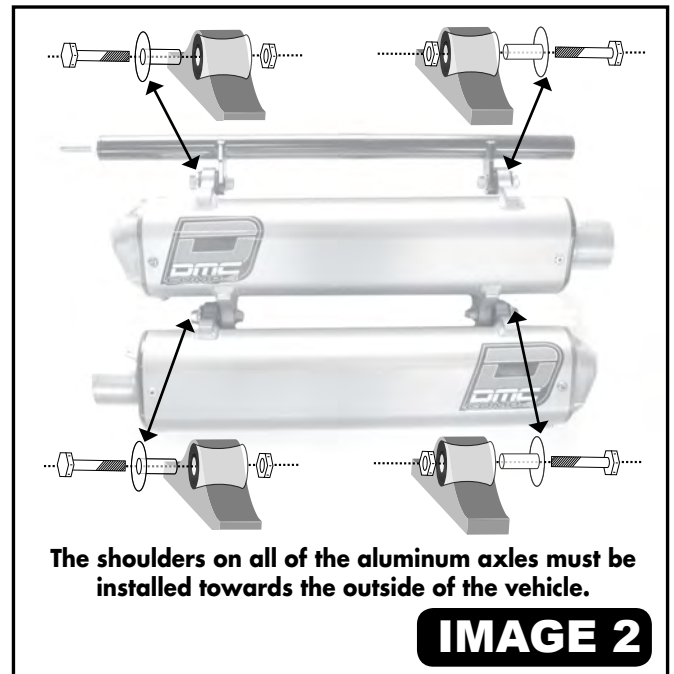

**The shoulders on all of the aluminum axles must be installed towards the outside of the vehicle.**

**IMAGE 2**

## SYSTEM INSTALLATION

1. Once both mufflers are bolted to the DMC Muffler hanger as an assembly, insert the tapered pin on the Muffler Hanger into the stock left side rubber frame mount used by the stock muffler hanger.
2. Install the supplied 8 mm flange bolt into the threaded right side of the Muffler Hanger to secure the DMC Muffler Hanger. **Use medium strength loctite** or another brand of thread locking fluid on these threads to eliminate this screw from loosening!
3. Install the left (drivers side) Mid-Pipe into the lower muffler, and install the springs to secure the DMC Mid-Pipe to the muffler. **SEE IMAGE #4 (next page)**
4. Install the right (passenger side) Mid-Pipe into the upper DMC muffler, and install the springs to secure the DMC Mid-Pipe to the muffler.
5. Examine both exhaust gaskets, and if they are damaged, replace them at this time.
6. Starting with the left (drivers side) align and fasten the DMC header to the cylinder head using the three stock socket head cap screws. Leave these screws loose for now.
7. Align and fasten the right (passenger side) DMC header to the cylinder head using the three stock socket head cap screws. Leave these screws loose for now.
8. Install the spring that secures the mid pipe to the header on both the right and left side of vehicle. **SEE IMAGE #5 (next page)**
9. Tighten the six socket head cap screws that secure the header flanges to the cylinder head.
10. Rotate/align the mufflers so that the tops of the mufflers are level and then tighten all four muffler bracket mounts. **SEE IMAGE #6 (next page) FOR OVERVIEW**



**IMAGE 3**

## SAFETY AND INSPECTION

1. Inspect the entire installation very carefully to insure that the exhaust pipes and mufflers are not close to, or come in contact with any cables, hoses, frame, covers, etc.

## RE-ASSEMBLY

1. Replace the plastic panel directly behind seats.
2. Re-install the seats.
3. After completing installation, start your engine in a well-ventilated area and listen for exhaust leaks. We recommend driving for 30 minutes to allow components to properly seat. Allow engine and exhaust system to completely cool down before re-checking all fasteners, especially the exhaust flange screws. All set? Go have a blast!

## EFI CONTROL/AIR FUEL MIX

Your RZR XP900 is a high performance vehicle, and the addition of this tuned/free flowing exhaust requires the installation of a DMC EFI Controller. Failure to install this controller reduces overall performance and shortens muffler-packing life. Order from your DMC dealer or online at:

[www.dmc-on-line.com](http://www.dmc-on-line.com)  
Part # 25990-32

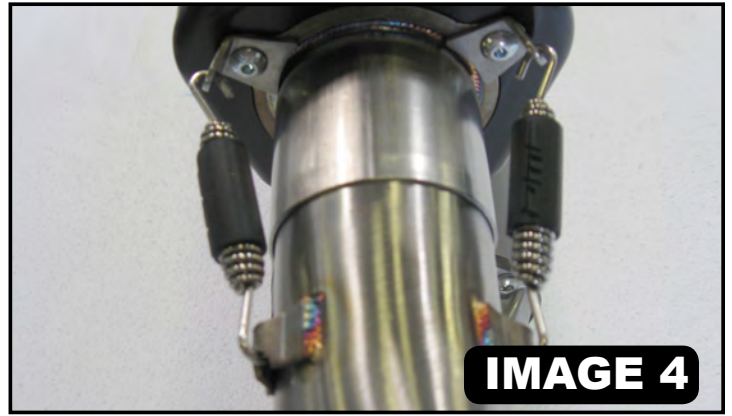

IMAGE 4

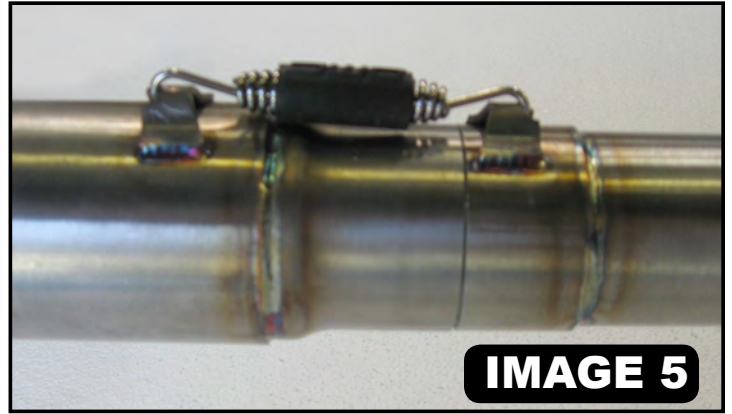

IMAGE 5

## MAINTENANCE

Please allow exhaust system to cool prior to washing or repair. DMC recommends using a mild soap such as dish detergent and water to wash your exhaust system. Also, you should not allow water to enter the silencer outlet while washing your bike or ATV.

As we all know, sound is a major issue, which can effect whether or not we continue to enjoy our sport without offending others. Also, your system performs best and will last longer when the silencer is properly maintained. Repacking your silencer depends on the type of riding and the amount of hours on the bike.

On a big-bore-four, frequent high speed riding will shorten the life of the packing. Your ears are the best guide to knowing when to repack, but as a rule, every 20-30 hours is a good guideline to inspect and replace if necessary. If and when it is time to repack, please use DMC Afterburner Repack Kits as they were tested and designed to provide the best performance.

To keep your spark arrestor clean, first remove it from your muffler, then use a soft bristled brush and soapy water.



IMAGE 6

## EXHAUST REPLACEMENT PARTS

USFS Approved Spark Arrestor	#25911-10
S.O.S. Quiet Core Insert	#25911-20
DMC Afterburner Repack Kit (Quiet Mufflers)	#25911-46
Afterburner Replacement Springs (pair)	#25911-50

## WARRANTY

Since we designed, developed and manufactured your DMC Exhaust to provide reliable performance, we guarantee your system for one year (from date of purchase) against defects in materials and workmanship. We are proud of our attention to the quality of manufacturing your DMC product and we stand behind our products. In the unlikely event a problem arises with your system, please contact the dealer from whom it was purchased. They can contact DMC and get your system to us for a warranty determination. A copy of your receipt will be required. We will make every attempt for a prompt repair or replacement at our determination and expense. It is important to note that our warranty is not unconditional. Although your DMC product was made with the finest materials and hand crafted to strict stands, it is not indestructible. Therefore, our warranty does not cover product damage as a result from abuse, misuse, improper installation, modifications or lack of maintenance. We also do not cover any damages whether consequential, incidental, special, contingent or otherwise: or expenses or injury arising directly or indirectly from the use the use of the exhaust system. As with any product, your DMC system should be expected to experience normal wear, which is not covered by any warranty. The duration of any and all implied warranties are limited to the duration of the express warranty.

## TECH SUPPORT

If you ever lose your instructions or need additional information, simply visit the DMC website where we offer all the installation information that came with your DMC exhaust. If, at any time, there is further news regarding modifications, jetting adjustments, or other, the DMC website is a great source for obtaining the latest news.

[www.spectro-oils.com](http://www.spectro-oils.com)



**DMC recommends using Spectro Oils for maximum protection.**



930 Columbia Avenue  
Riverside, CA 92507

[www.dmc-on-line.com](http://www.dmc-on-line.com)